

THIS DRAWING IS UNPUBLISHED. RELEASED FOR PUBLICATION
 © COPYRIGHT BY TYCO ELECTRONICS CORPORATION. ALL RIGHTS RESERVED.

LOC		DIST		REVISIONS					
AF		50		P	LTR	DESCRIPTION	DATE	DWN	APVD
				AB		REVISED PER 0G3A-0170-05	30JUN05	MF	EH

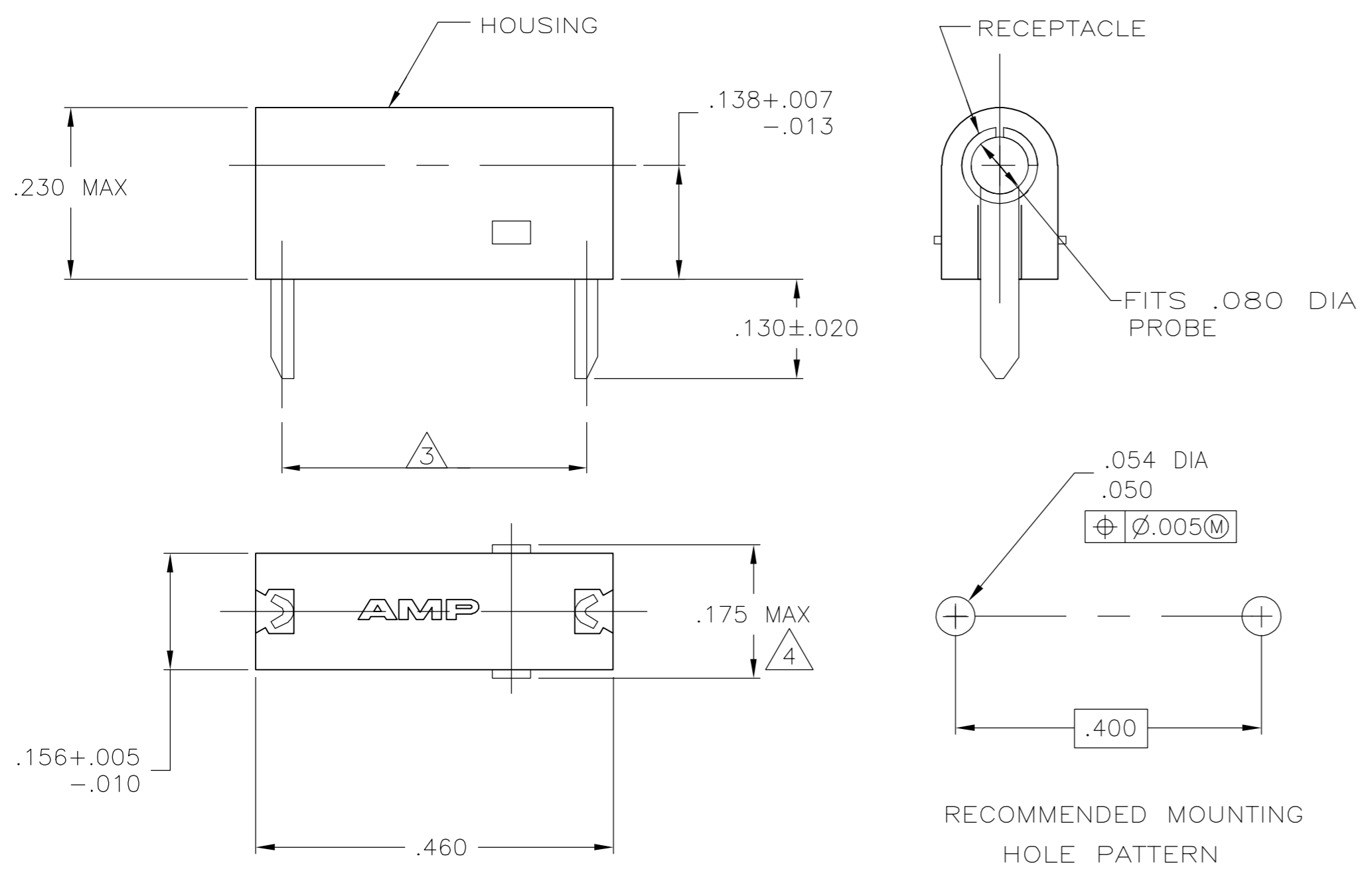

- 1 OPERATION TEMPERATURE IS 105° C MAX.
- 2 RETENTION FORCE - 16 OUNCES MIN INITIALLY.
6 OUNCES MIN AFTER 500 CYCLES.
- 3 REFER TO MOUNTING HOLE PATTERN.
- 4 .175 MAX TO BE MEASURED ACROSS THE CUT-OFF TABS.

	NYLON 6/6; WHITE	BRASS - GOLD	3-582118-9
OBSOLETE	NYLON 6/6; GRAY	BRASS - GOLD	3-582118-8
	NYLON 6/6; VIOLET	BRASS - GOLD	3-582118-7
	NYLON 6/6; BLUE	BRASS - GOLD	3-582118-6
	NYLON 6/6; GREEN	BRASS - GOLD	3-582118-5
	NYLON 6/6; YELLOW	BRASS - GOLD	3-582118-4
	NYLON 6/6; ORANGE	BRASS - GOLD	3-582118-3
	NYLON 6/6; RED	BRASS - GOLD	3-582118-2
OBSOLETE	NYLON 6/6; BROWN	BRASS - GOLD	3-582118-1
	NYLON 6/6; BLACK	BRASS - GOLD	3-582118-0
	NYLON 6/6; WHITE	BRASS - SILVER	2-582118-9
OBSOLETE	NYLON 6/6; GRAY	BRASS - SILVER	2-582118-8
OBSOLETE	NYLON 6/6; VIOLET	BRASS - SILVER	2-582118-7
	NYLON 6/6; BLUE	BRASS - SILVER	2-582118-6
OBSOLETE	NYLON 6/6; GREEN	BRASS - SILVER	2-582118-5
OBSOLETE	NYLON 6/6; YELLOW	BRASS - SILVER	2-582118-4
OBSOLETE	NYLON 6/6; ORANGE	BRASS - SILVER	2-582118-3
	NYLON 6/6; RED	BRASS - SILVER	2-582118-2
OBSOLETE	NYLON 6/6; BROWN	BRASS - SILVER	2-582118-1
	NYLON 6/6; BLACK	BRASS - SILVER	2-582118-0
	NYLON 6/6; WHITE	BRASS - TIN	1-582118-9
OBSOLETE	NYLON 6/6; GRAY	BRASS - TIN	1-582118-8
OBSOLETE	NYLON 6/6; VIOLET	BRASS - TIN	1-582118-7
OBSOLETE	NYLON 6/6; BLUE	BRASS - TIN	1-582118-6
	NYLON 6/6; GREEN	BRASS - TIN	1-582118-5
	NYLON 6/6; YELLOW	BRASS - TIN	1-582118-4
OBSOLETE	NYLON 6/6; ORANGE	BRASS - TIN	1-582118-3
	NYLON 6/6; RED	BRASS - TIN	1-582118-2
OBSOLETE	NYLON 6/6; BROWN	BRASS - TIN	1-582118-1
	NYLON 6/6; BLACK	BRASS - TIN	1-582118-0

	NYLON 6/6; NATURAL	BRASS - GOLD	6-582118-9
OBSOLETE	NYLON 6/6; NATURAL	BRASS - SILVER	5-582118-9
	HOUSING - MATERIAL; COLOR	RECEPTACLE - MATERIAL; FINISH	PART NUMBER

THIS DRAWING IS A CONTROLLED DOCUMENT.

DWN: M.S. FEHER 13APR2004
 CHK: E. HOWARD 13APR2004
 APVD: E. HOWARD 13APR2004

tyco Electronics Tyco Electronics Corporation
 Harrisburg, Pa 17105-3608

NAME: ASSEMBLY, TEST PROBE

SIZE: A2 CAGE CODE: 00779 DRAWING NO: C=582118 RESTRICTED TO: -

MATERIAL: SEE TABLE DIMENSIONS: mm TOLERANCES UNLESS OTHERWISE SPECIFIED: 0 PLC ± - 1 PLC ± - 2 PLC ± .015 3 PLC ± - 4 PLC ± - ANGLES ± - FINISH: SEE TABLE WEIGHT: - SCALE: 6:1 SHEET 1 OF 1 REV AB